

Lectures prepared by:
Elchanan Mossel
Yelena Shvets

Follows Jim Pitman's
book:
Probability
Sections 6.3

Conditional density

Example: (X, Y) uniform in the unit disk centered at 0 .

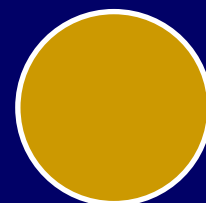

Question: $P(X > 0.1 | Y > 0.1) = ?$

Answer:
$$P(X > 0.1 | Y > 0.1) = \frac{P(X > 0.1 \ \& \ Y > 0.1)}{P(Y > 0.1)}$$

Question: $P(X > 0.1 | Y = 0.1) = ?$

Try:
$$P(X > 0.1 | Y = 0.1) = \frac{P(X > 0.1 \ \& \ Y = 0.1)}{P(Y = 0.1)} = \frac{0}{0}!$$

Infinitesimal Conditioning Formula

Solution: Replace by infinitesimal ratio:

$$P[A|X = x] = \lim_{dx \rightarrow 0} \frac{P[A, X \in (x, x + dx)]}{P[X \in (x, x + dx)]}$$

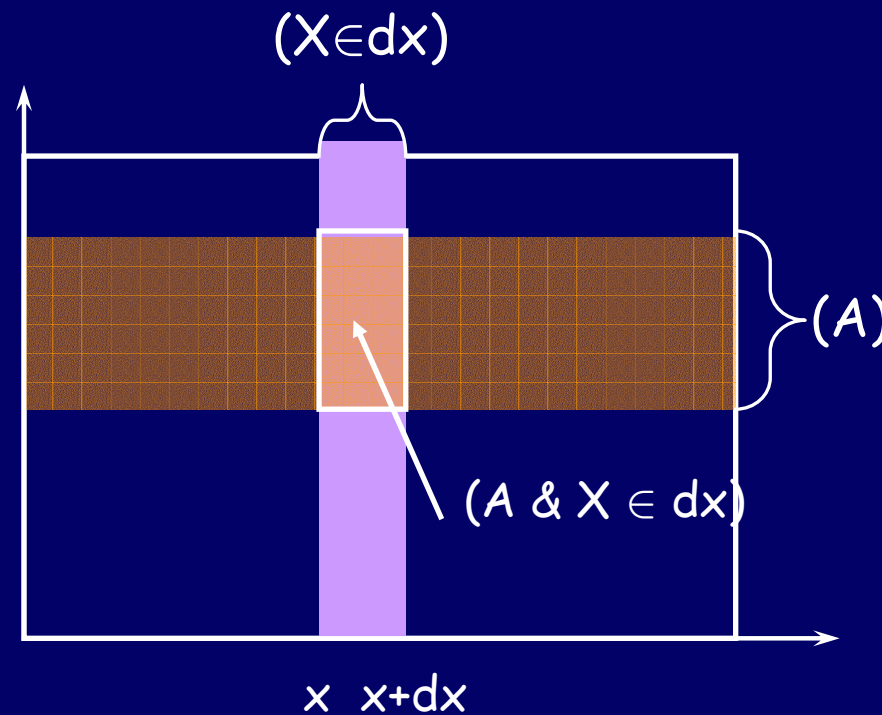

Infinitesimal Conditioning Formula

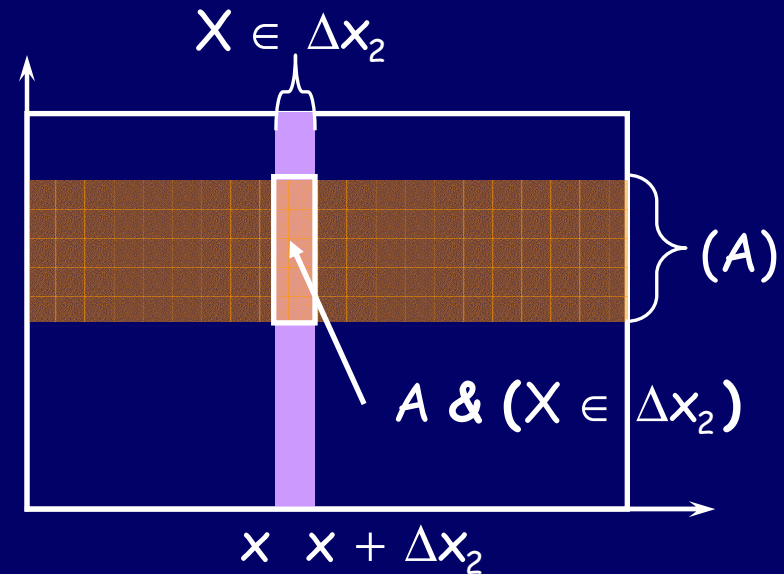
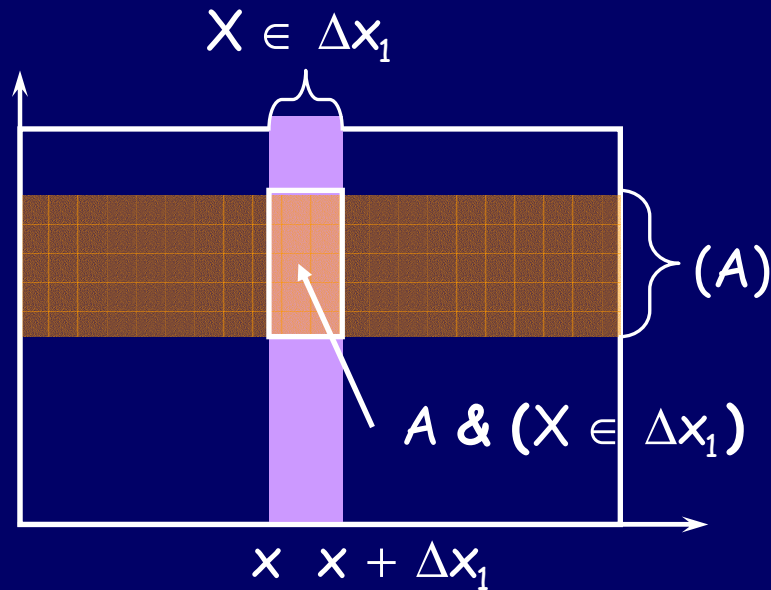

$$\begin{aligned} P(A \mid X = x) &= \lim_{\Delta x \rightarrow 0} \frac{P(A \mid X \in \Delta x)}{P(X \in \Delta x)} \\ &= \lim_{\Delta x \rightarrow 0} \frac{P(A \& X \in \Delta x)}{P(X \in \Delta x)} \end{aligned}$$

Conditional Density

Claim: Suppose (X, Y) have a joint density $f(x, y)$, and x is such that $f_x(x) > 0$, the conditional density of Y given $X=x$ is a probability density defined by

$$f_y(y | X = x) = \frac{f(x, y)}{f_x(x)}$$

"Proof":

$$P(a \leq Y \leq b | X = x) =$$

$$\lim P(a \leq Y \leq b | X \in (x, x+dx)) =$$

$$\lim P(a \leq Y \leq b, X \in (x, x+dx)) / f_x(x) dx =$$

$$\lim \int_a^b f(x, y) dy dx / f_x(x) dx = \int_a^b f_y(y | X = x) dy$$

Conditional Density

Joint density of (X,Y) :
 $f(x,y)$:

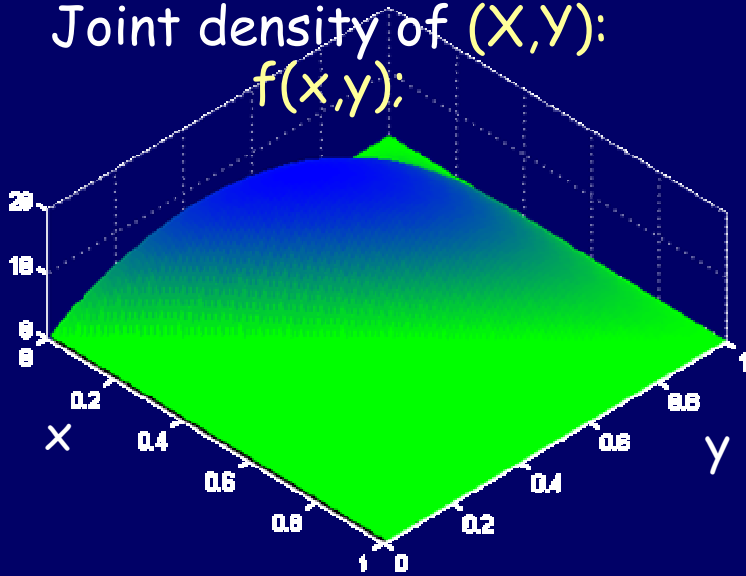

Renormalized slice for given $y =$
conditional density $P[X | Y=y]$,
The area is of each slice is 1.

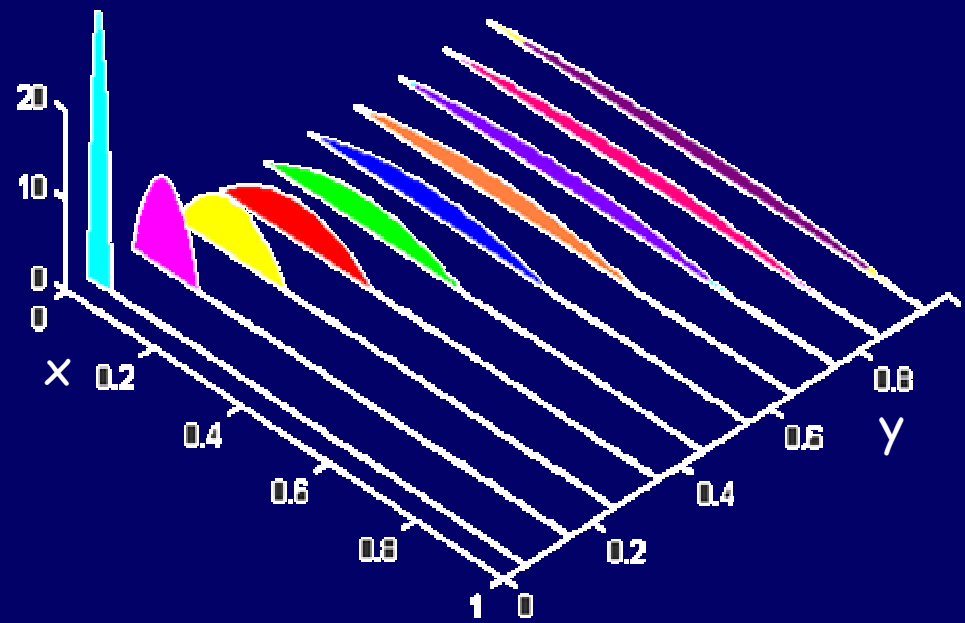

Slices through density for fixed y 's.

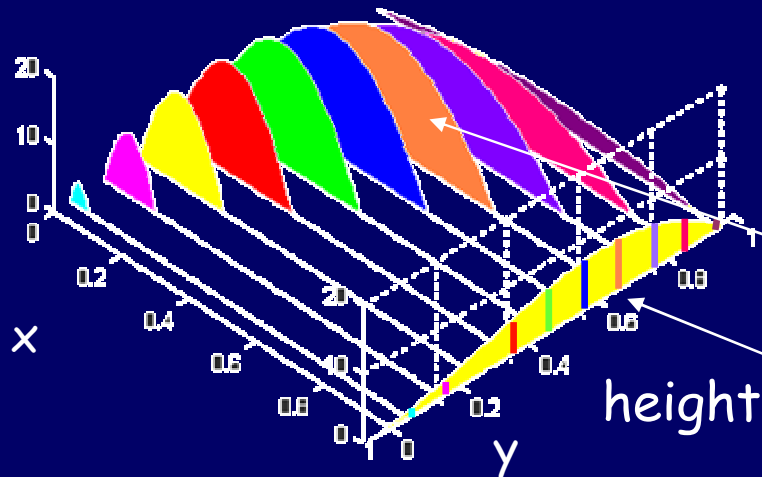

Area of slice at y

=

height of marginal distribution at y .

Conditioning Formulae

Discrete

Continuous

• Multiplication Rule:

$$P(x, y) = P(Y = y|X = x)P(X = x)$$

$$f(x, y) = f_Y(y|X = x)f_X(x)$$

• Division Rule:

$$P(Y = y|X = x) = \frac{P(X = x, Y = y)}{P(X = x)}$$

$$f_Y(y|X = x) = \frac{f(x, y)}{f_X(x)}$$

• Bayes' Rule:

$$P(X = x|Y = y) = \frac{P(Y = y|X = x)P(X = x)}{P(Y = y)}$$

$$f_X(x|Y = y) = \frac{f_Y(y|X = x)f_X(x)}{f_Y(y)}$$

Example: Uniform on a triangle.

Suppose that a point (X,Y) is chosen uniformly at random from the triangle $A: \{(x,y): 0 \leq x, 0 \leq y, x+y \leq 2\}$.

Question: Find $P(Y \geq 1 \mid X = x)$.

Solution 1: Since $\text{Area}(A) = 2$, for all S , $P(S) = \text{Area}(S)/2$.

So for $0 \leq x < 1$:

$$P(X \in \Delta x) = \frac{1}{2} \Delta x (2 - x - \frac{1}{2} \Delta x);$$

$$P(Y > 1, X \in \Delta x) = \frac{1}{2} \Delta x (1 - x - \frac{1}{2} \Delta x);$$

$$\begin{aligned} P(Y \geq 1 \mid X \in \Delta x) &= P(Y > 1, X \in \Delta x) / P(X \in \Delta x) \\ &= (1 - x - \frac{1}{2} \Delta x) / (2 - x - \frac{1}{2} \Delta x); \\ &\rightarrow (1 - x) / (2 - x) \text{ as } \Delta x \rightarrow 0. \end{aligned}$$

So $P(Y \geq 1 \mid X = x) = (1 - x) / (2 - x)$

And for $x \geq 1$: $P(Y \geq 1 \mid X = x) = 0$.

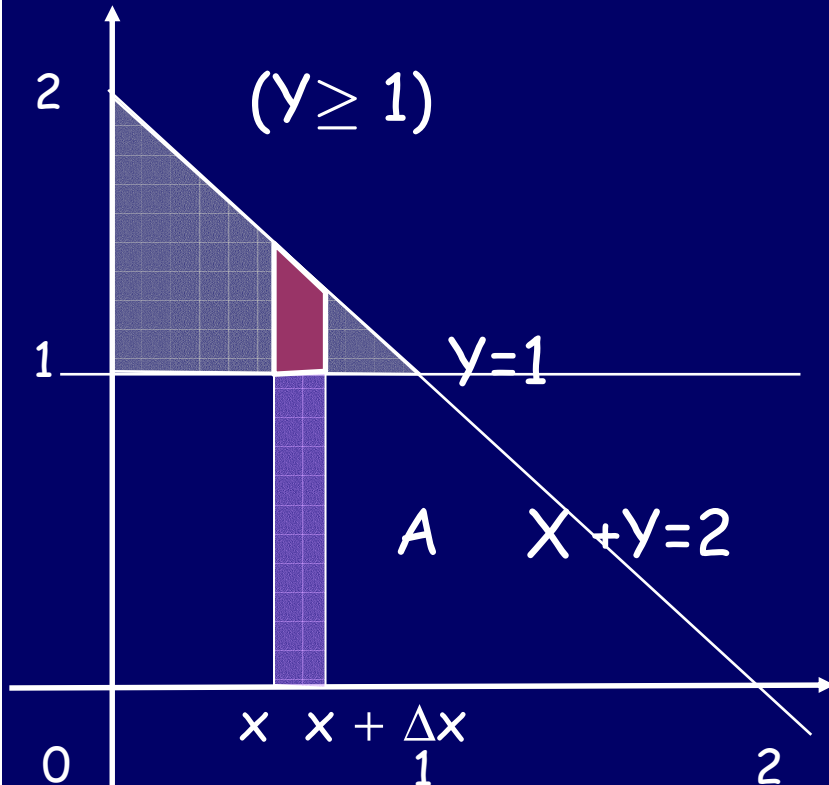

Example: Uniform on a triangle.

Suppose that a point (X,Y) is chosen uniformly at random from the triangle $A: \{(x,y): 0 \leq x, 0 \leq y, x+y \leq 2\}$.

Question: Find $P(Y \geq 1 \mid X = x)$.

Solution 2. using the conditional density $f_Y(y \mid X=x)$.

For the uniform distribution on a triangle of area 2,

$$f(x,y) = \begin{cases} 1/2, & \text{if } 0 \leq x, 0 \leq y, x+y \leq 2; \\ 0, & \text{otherwise.} \end{cases}$$

$$\text{So for } 0 \leq x \leq 2, \quad f_X(x) = \int_0^\infty f(x,y) dy = \int_0^{2-x} \frac{1}{2} dy = \frac{2-x}{2},$$

$$f_Y(y \mid X = x) = \begin{cases} \frac{f(x,y)}{f_X(x)} = \frac{1}{2-x} & \text{if } 0 \leq y \leq 2-x; \\ 0, & \text{otherwise.} \end{cases}$$

Given, $X=x$, the distribution of Y is uniform on $(0,2-x)$.

$$P[Y \geq 1 \mid X = x] = \int_1^{2-x} \frac{1}{2-x} dx = \frac{1-x}{2-x}.$$

Example: Gamma and Uniform

Suppose that X has $\text{Gamma}(2, \lambda)$ distribution, and that given $X=x$, Y has $\text{Uniform}(0, x)$ distribution.

Question: Find the joint density of X and Y

Solution:

By definition of $\text{Gamma}(2, \lambda)$ distr., $f_X(x) = \begin{cases} \lambda^2 x e^{-\lambda x}, & \text{if } 0 < x; \\ 0, & \text{otherwise.} \end{cases}$

By definition of $\text{Unif}(0, x)$, $f_Y(y|X = x) = \begin{cases} \frac{1}{x}, & \text{if } 0 < y < x; \\ 0, & \text{otherwise.} \end{cases}$

By multiplication rule, $f(x, y) = f_Y(y|X = x)f_X(x) = \begin{cases} \lambda^2 e^{-\lambda x}, & \text{if } 0 < y < x; \\ 0, & \text{otherwise.} \end{cases}$

Question: Find the marginal density of Y .

Solution: $f_Y(y) = \int_0^\infty f(x, y) dx = \int_y^\infty \lambda^2 e^{-\lambda x} dx = \lambda e^{-\lambda y}$.

So $Y \sim \text{Exp}(\lambda)$.

Condition Distribution & Expectations

Discrete

Continuous

- Conditional distribution of Y given $X=x$;

$$P(Y \in B|X = x) = \sum_{y \in B} P(Y = y|X = x)$$

$$P(Y \in B|X = x) = \int_B f_Y(y|X = x) dy$$

- Expectation of a function $g(X)$:

$$E(g(Y)|X = x) = \sum_{\text{all } y} g(y)P(Y = y|X = x)$$

$$E(g(Y)|X = x) = \int g(y)f_Y(y|X = x) dy$$

Independence

Conditional distribution of Y given $X=x$ does not depend on x :

$$P(Y \in B | X=x) = P(Y \in B).$$

Conditional distribution of X given $Y=y$ does not depend on y :

$$P(X \in A | Y=y) = P(X \in A).$$

The multiplication rule reduces to:

$$f(x,y) = f_X(x)f_Y(y).$$

Expectation of the product is the product of Expectations:

$$E(XY) = \int \int xy f_X(x) f_Y(y) dx dy = E(X) E(Y).$$

Example: (X, Y) Uniform on a Unit Circle.

$$f(x, y) = \begin{cases} \frac{1}{\pi}, & \text{if } x^2 + y^2 < 1; \\ 0, & \text{otherwise.} \end{cases}$$

Question: Are X and Y independent?

Solution:

$$f_X(x|Y = y) = \begin{cases} \frac{1}{2\sqrt{1-y^2}}, & \text{if } -\sqrt{1-y^2} < x < \sqrt{1-y^2}; \\ 0, & \text{otherwise.} \end{cases}$$

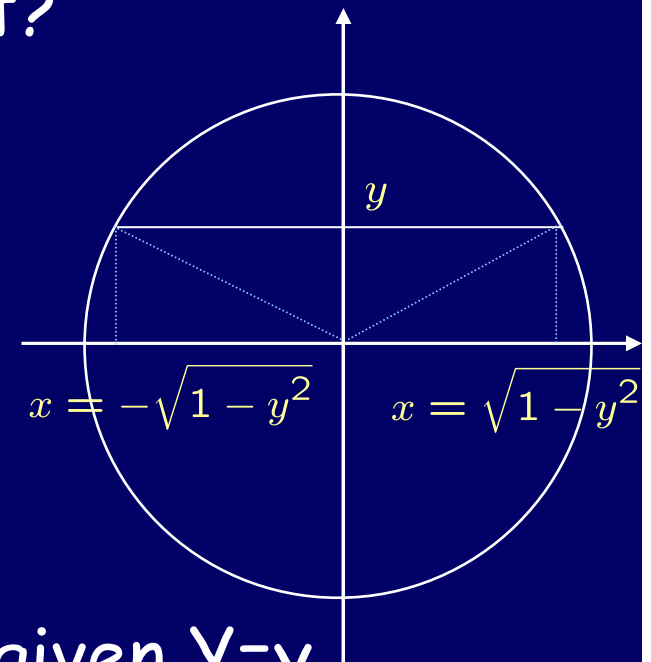

So the conditional distribution of X given $Y=y$ depends on y and hence X and Y cannot be independent. However, note that for all x and y

$$E(X|Y = y) = E(X) = 0 \text{ and } E(Y|X=x) = E(Y) = 0$$

Average Conditional Probabilities & Expectations

Discrete

Continuous

• Average conditional probability:

$$P(B) = \sum_{\text{all } x} P(B|X = x)P(X = x)$$

$$P(B) = \int P(B|X = x)f_X(x) dx$$

$$P(Y = y) = \sum_{\text{all } x} P(Y = y|X = x)P(X = x)$$

$$f_Y(y) = \int f_Y(y|X = x)f_X(x) dx$$

• Average conditional expectation:

$$E(Y) = \sum_{\text{all } x} E(Y|X = x)P(X = x)$$

$$E(Y) = \int E(Y|X = x)f_X(x) dx$$